

OHIO SCIENTIFIC
OHIO SCIENTIFIC
OHIO SCIENTIFIC
OHIO SCIENTIFIC
OHIO SCIENTIFIC

Serviceing Data

CALL TODAY FOR YOUR OWNERS
2 YEAR WARRANTY SOFTWARE
CONTACT US NOW

for
**COMPUTER BOARDS 470 (Floppy), 505 Rev. A,
510 Rev. C, 520 Rev. B, 520 Rev. C, 525, 527,
535, 550, 555, 590, 592, 594**

as used in

Challenger II and III Series

Models

C2-OEM
C3-OEM
C3-A
C3-B
C3-C
C3-S1



TABLE OF CONTENTS

	Page
Block Diagrams	
470 (Floppy) Board	31,32
505 Rev. A Board	41,42
510 Rev. C Board	56,57,58
520 Rev. B Board	81
520 Rev. C Board	81
525 Board	91
527 Board	105
535 Board	106
550 Board	108
555 Board	150
590 Board	155,156
592 Board	165
594 Board	173
General Servicing/Safety Precautions	1
Legends	
470 (Floppy) Board	177
505 Rev. A Board	177,178
510 Rev. C Board	178,179
520 Rev. B Board	179
520 Rev. C Board	179
525 Board	179
527 Board	179,180
535 Board	180
550 Board	180
555 Board	180,181
590 Board	181,182
592 Board	182, Rear Cover
594 Board	Rear Cover
Memory Maps	28,29
Model Description	2,3,4,5
Parts List	6 thru 27
Photos	
470 (Floppy) Board	33,34
505 Rev. A Board	43,44,45,46
510 Rev. C Board	59,60,61,62
520 Rev. B Board	74,75
520 Rev. C Board	83,84,89,90
525 Board	92
527 Board	98,99
535 Board	109 thru 112
550 Board	119 thru 122
555 Board	135 thru 138
590 Board	151 thru 154
592 Board	167,168
594 Board	175

Bunch of pages missing from here to Page 147

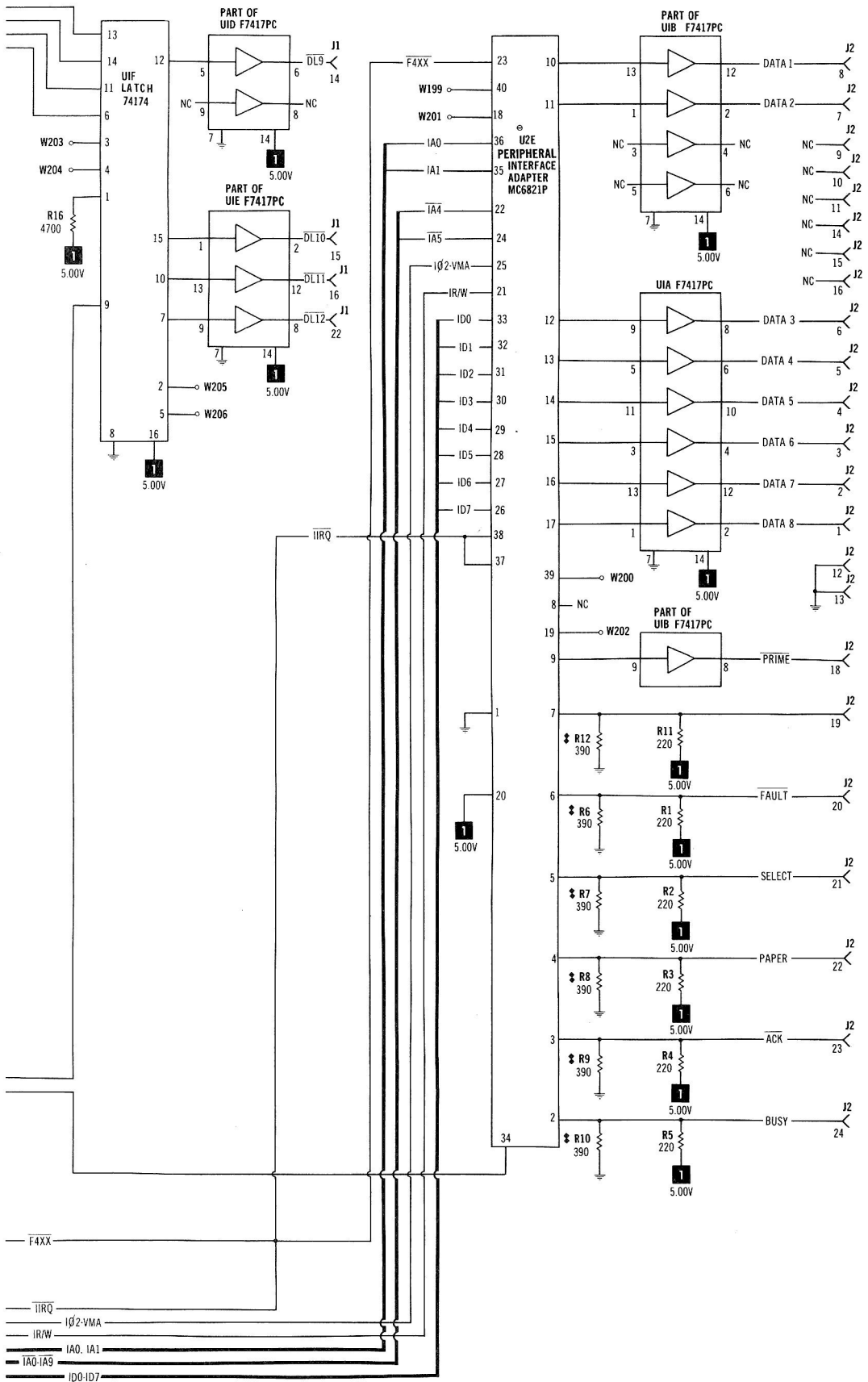

A PHOTOFACIT STANDARD NOTATION SCHEMATIC

WITH **CIRCUITTRACE™**

© Howard W. Sams & Co., Inc. 1980

**FOR SCHEMATIC LEGEND AND NOTES
SEE PAGES 180, 181 & REAR COVER.**

555 BOARD

555 BOARD PINOUTS

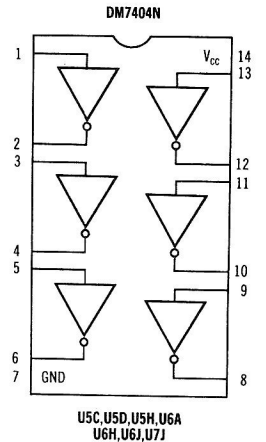
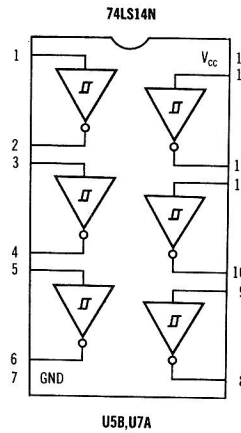
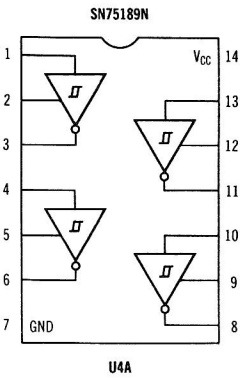
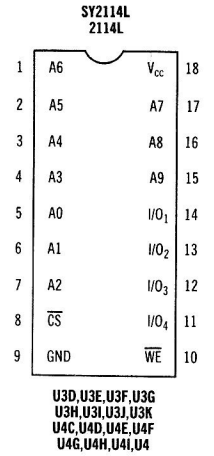
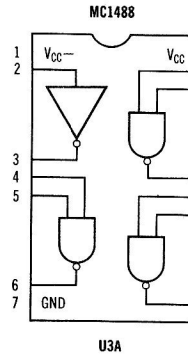
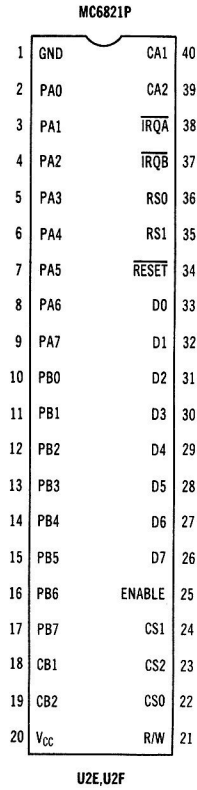
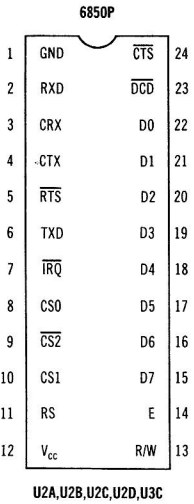
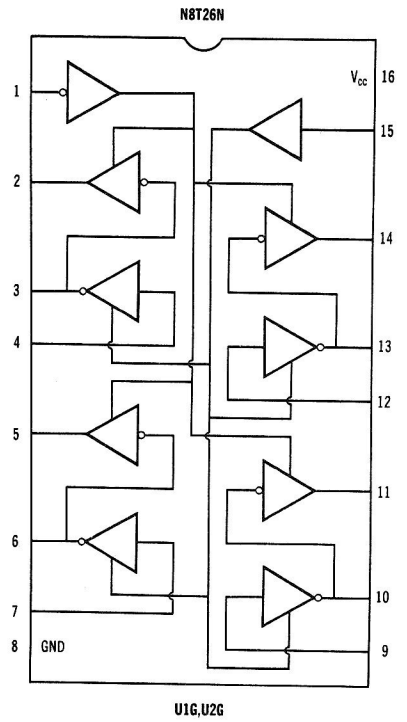
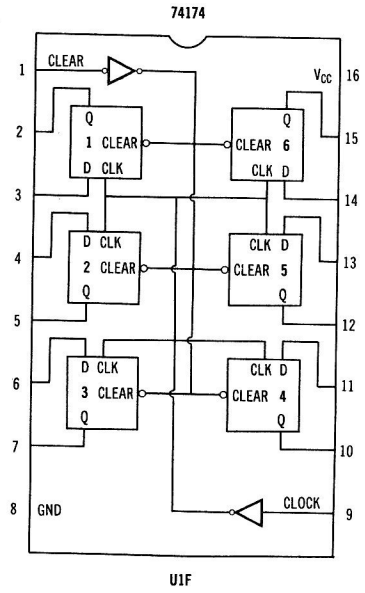
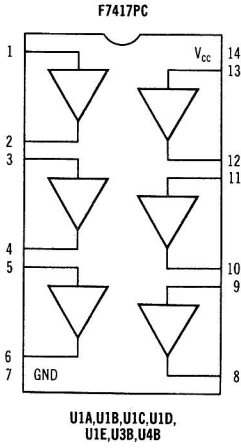

555 BOARD PINOUTS

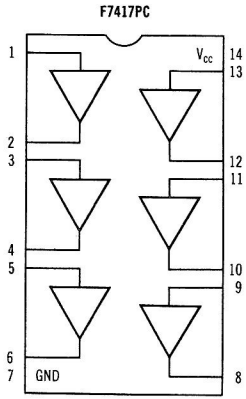

U1A,U1B,U1C,U1D,
U1E,U3B,U4B

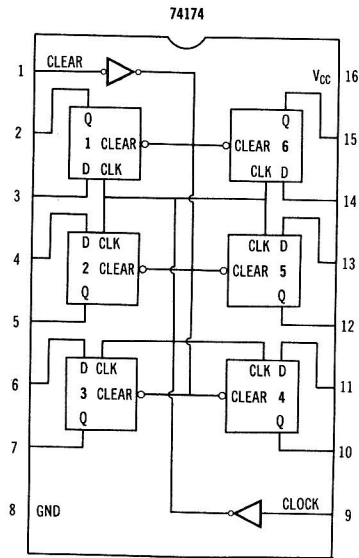

U1F

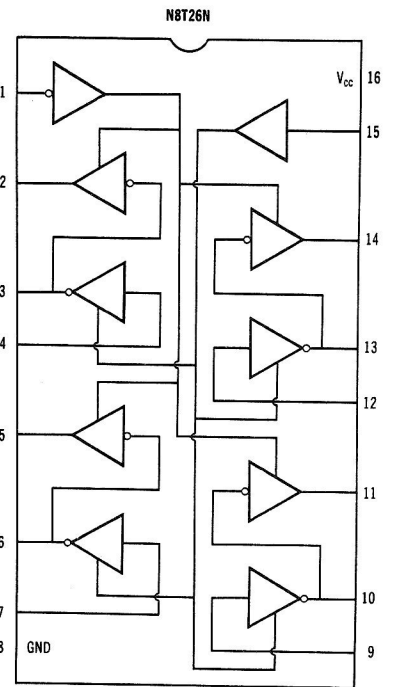

U16,U2G

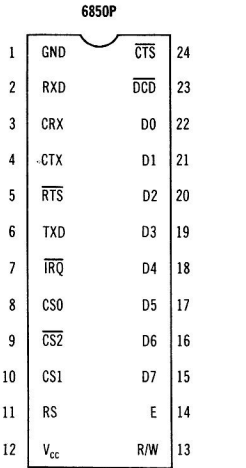

U2A,U2B,U2C,U2D,U3C

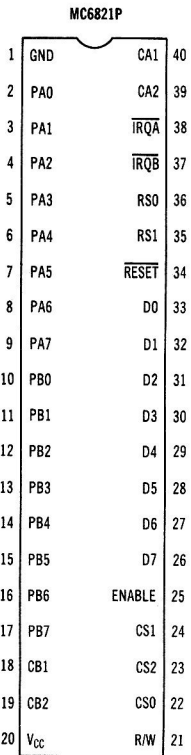

U2E,U2F

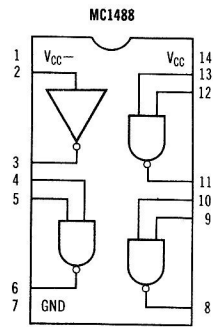

U3A

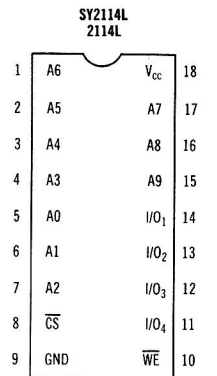

U3D,U3E,U3F,U3G
U3H,U3I,U3J,U3K
U4C,U4D,U4E,U4F
U4G,U4H,U4I,U4J

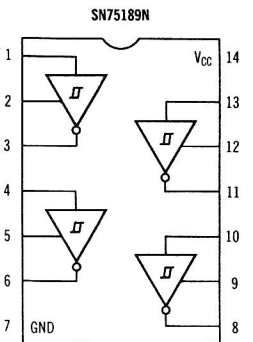

U4A

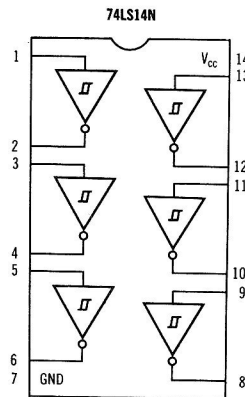

U5B,U7A

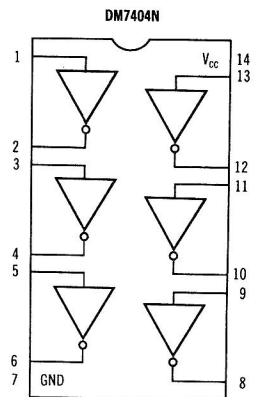

U5C,U5D,U5H,U6A
U6H,U6I,U7J

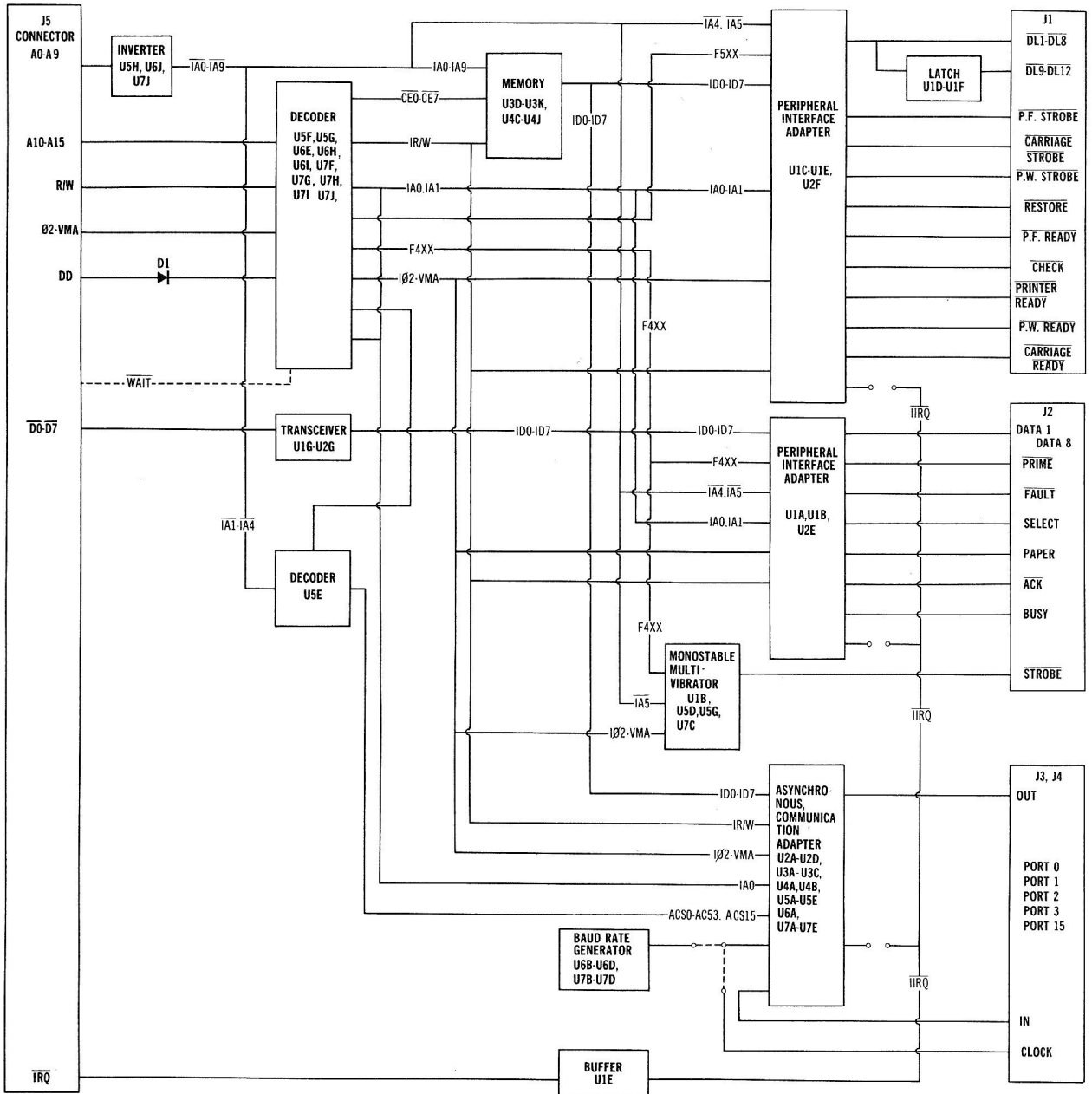

555 BOARD BLOCK

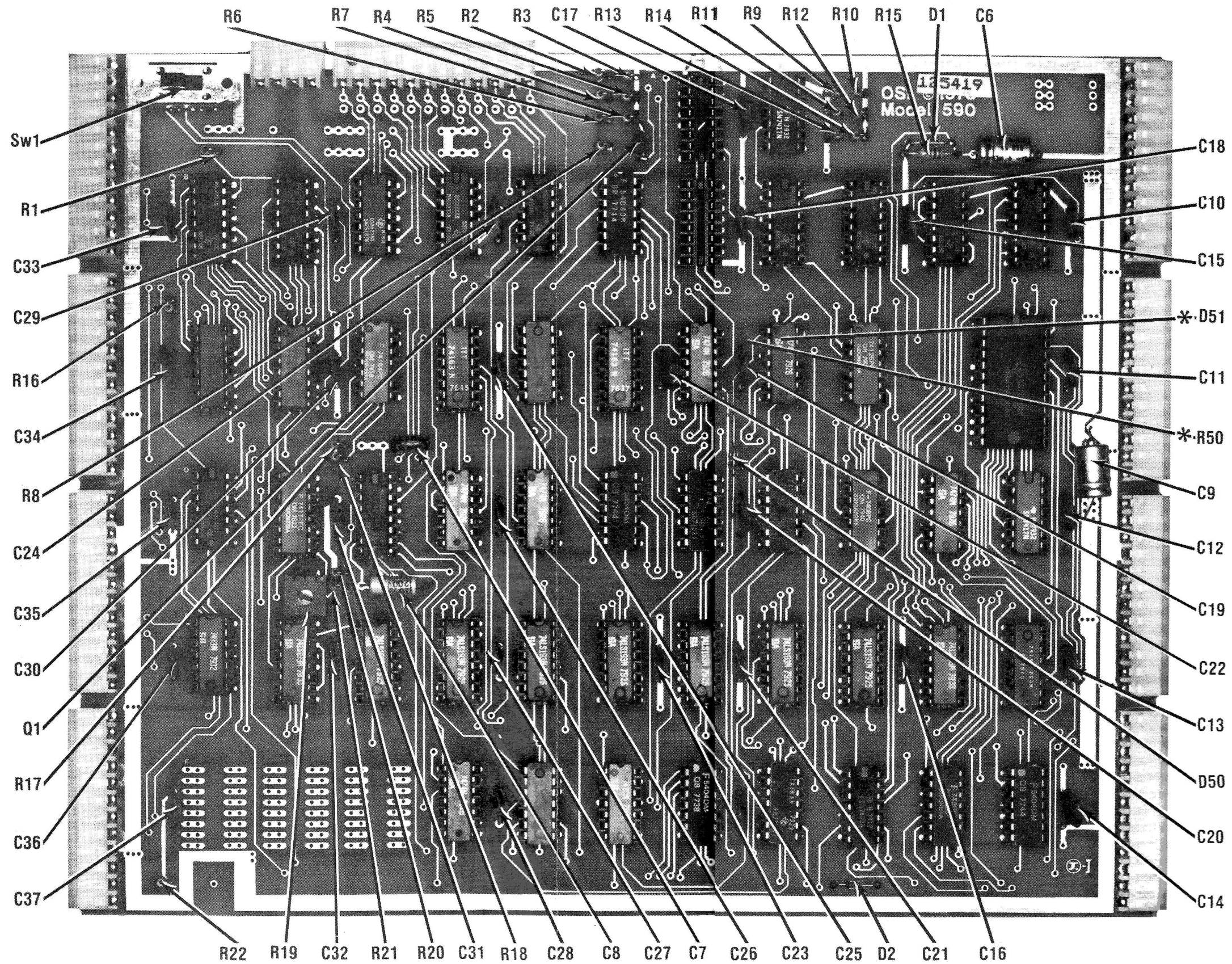

* LOCATED OTHER SIDE OF BOARD

590 BOARD
151

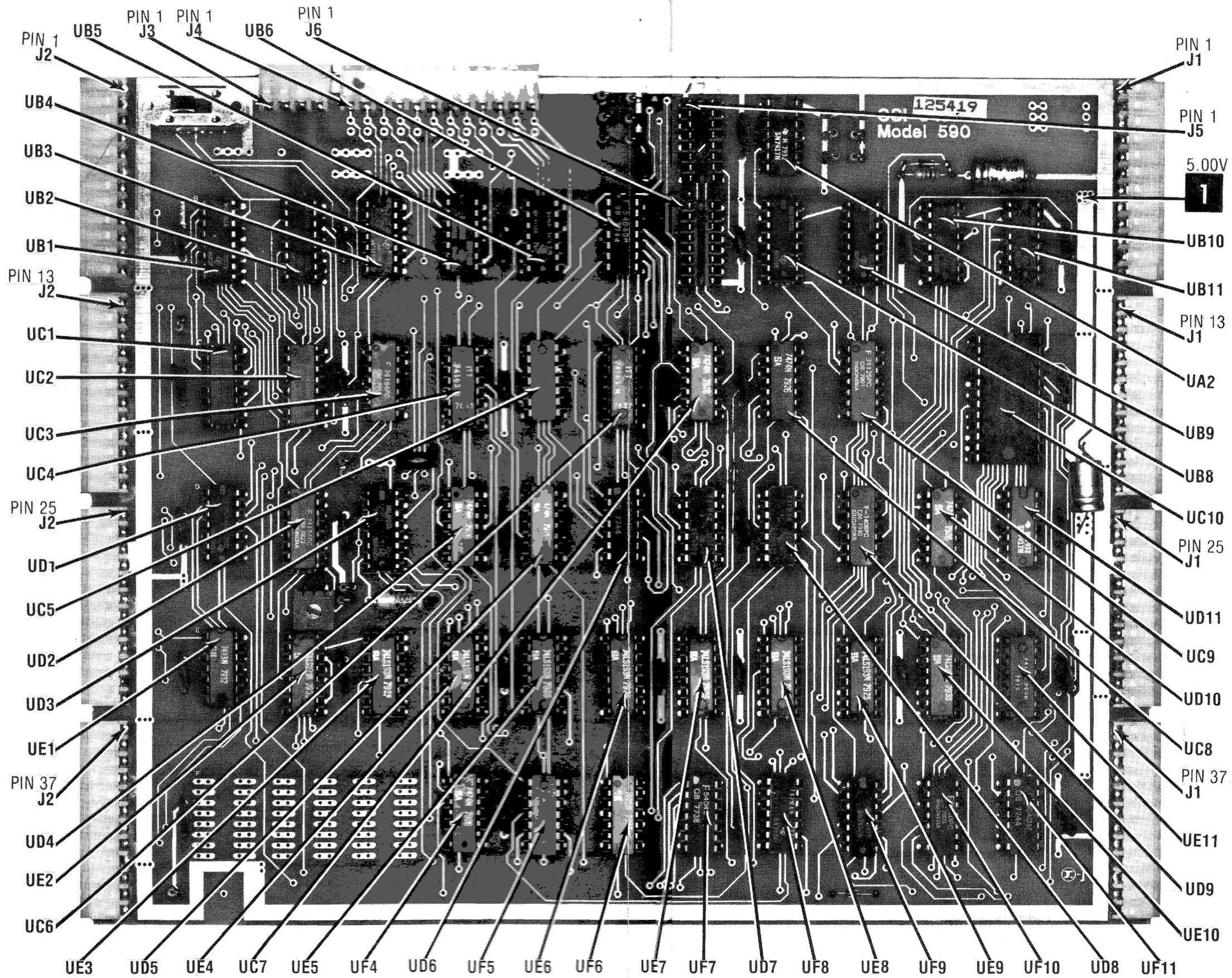

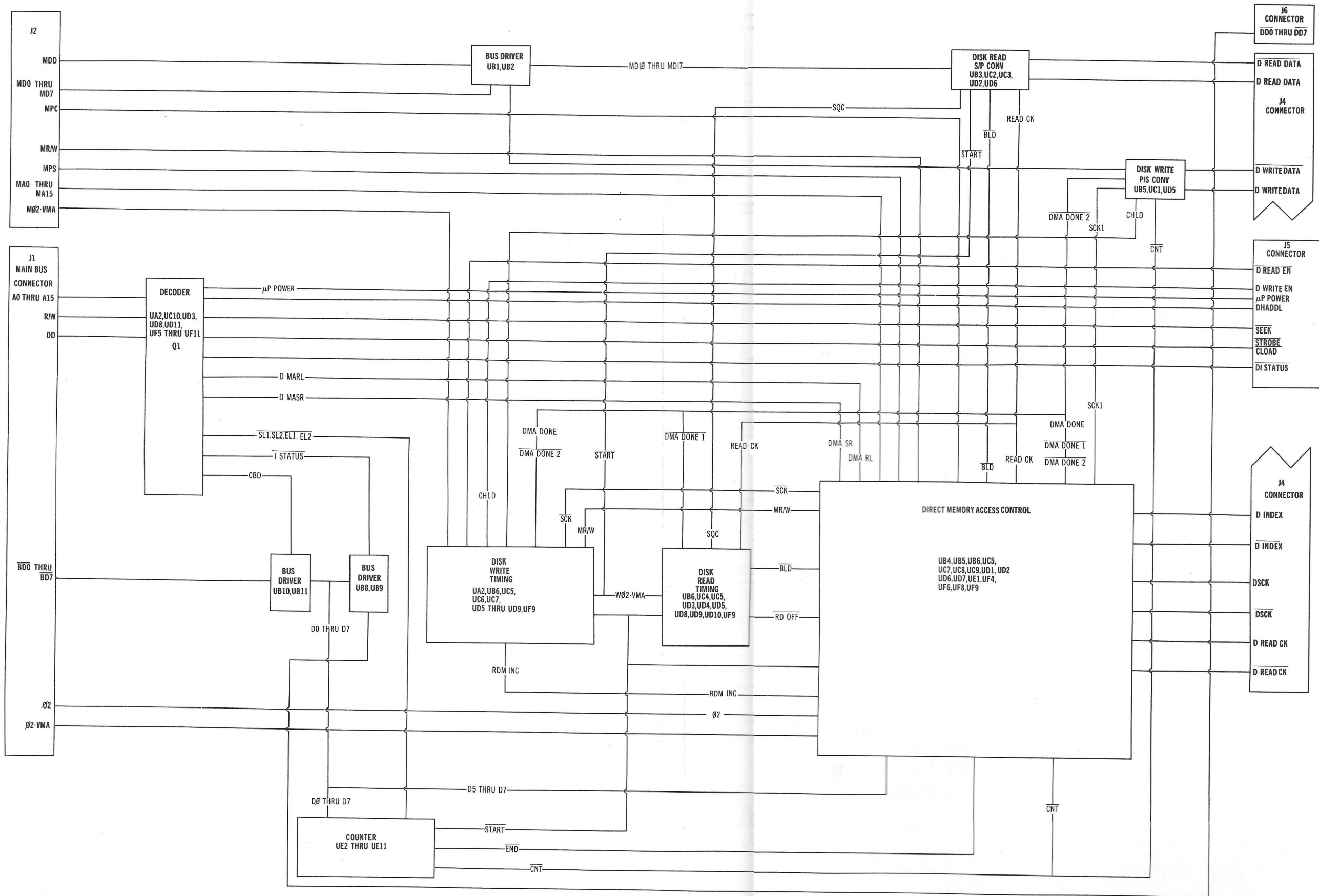

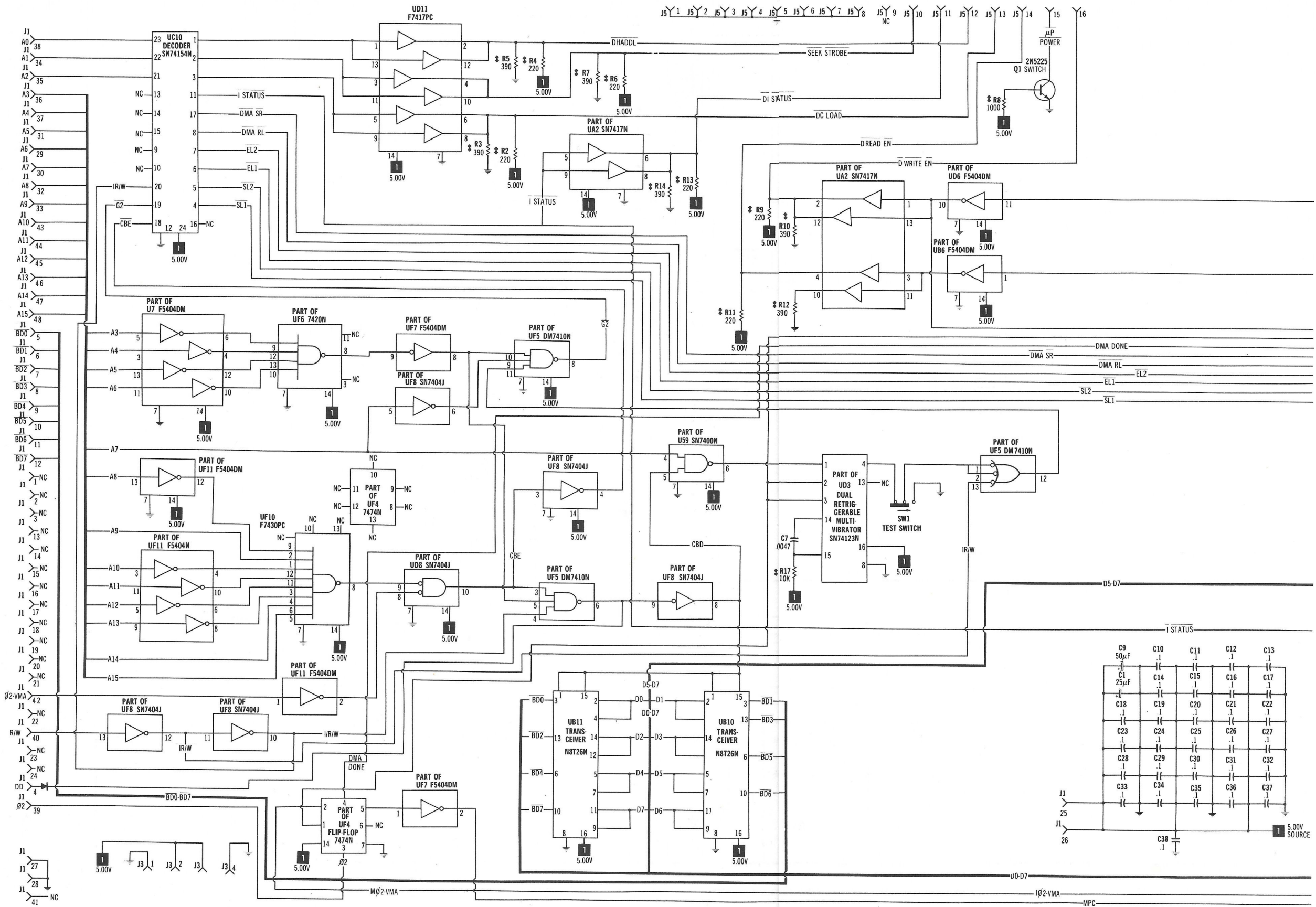

C9	50µF	C10	.1	C11	.1	C12	.1	C13	.1
C1	25µF	C14	.1	C15	.1	C16	.1	C17	.1
C18	.1	C19	.1	C20	.1	C21	.1	C22	.1
C23	.1	C24	.1	C25	.1	C26	.1	C27	.1
C28	.1	C29	.1	C30	.1	C31	.1	C32	.1
C33	.1	C34	.1	C35	.1	C36	.1	C37	.1
									5.00V SOURCE
									C38 .1

A PHOTOFAC STANDARD NOTATION SCHEMATIC
 WITH **CIRCUITRACE**[®]
 © Howard W. Sams & Co., Inc. 1980

FOR SCHEMATIC LEGEND AND NOTES SEE PAGES 181, 182 & REAR COVER.

590 BOARD

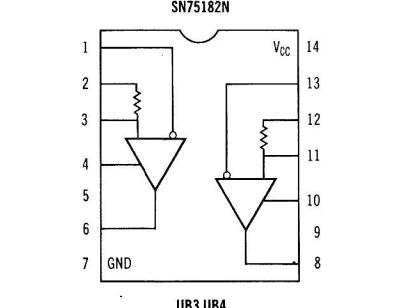
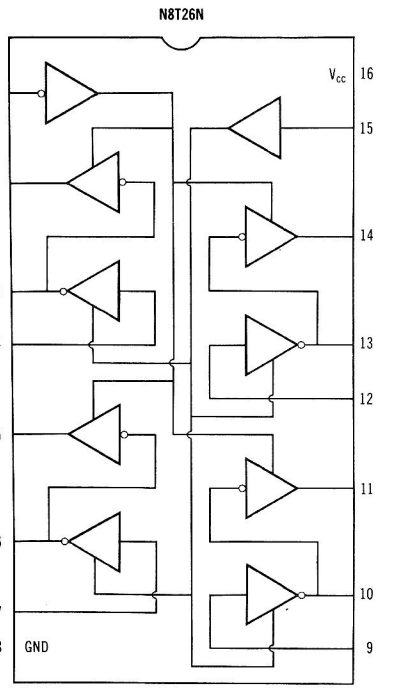
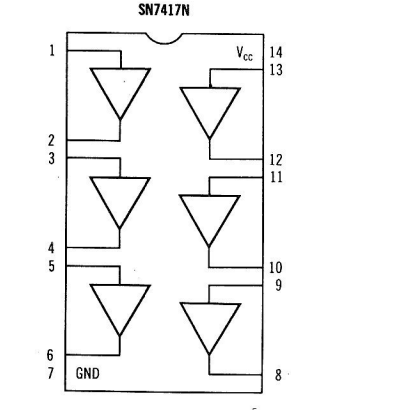
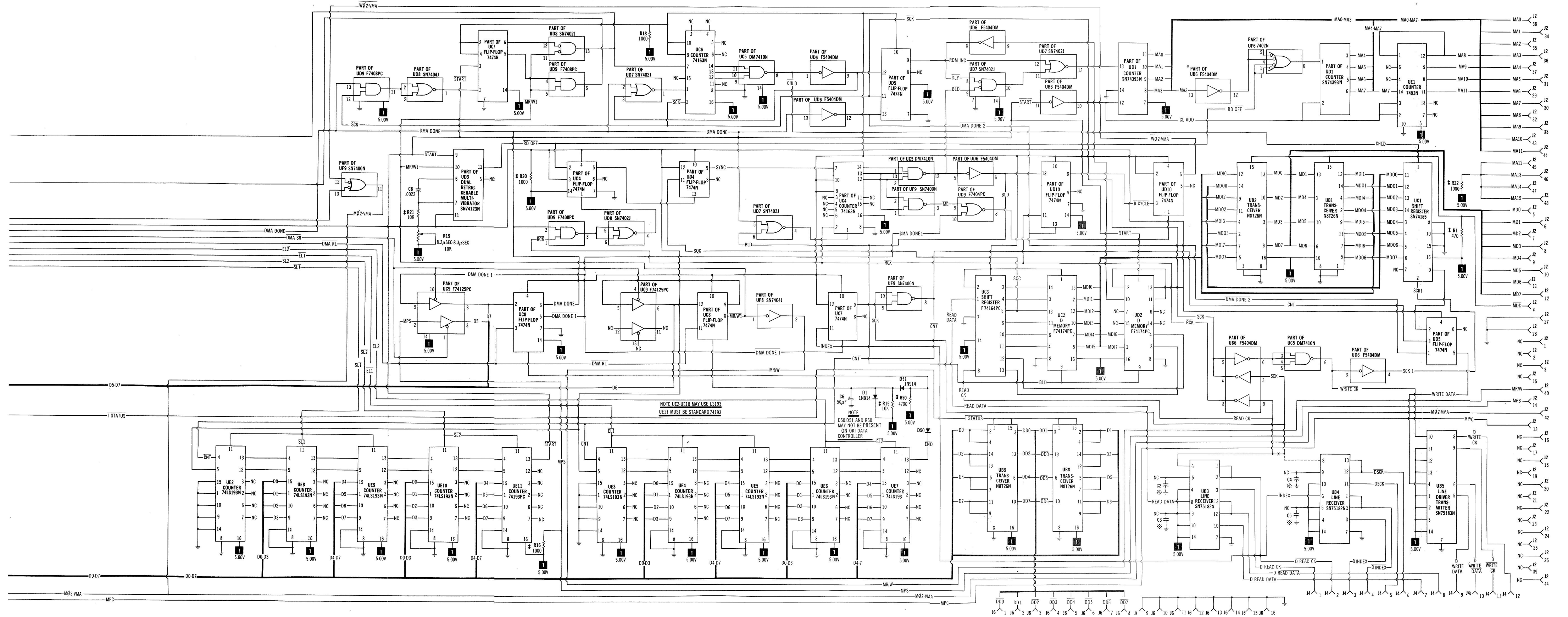

590 BOARD PINOUTS (CONTINUED)

SN75183N

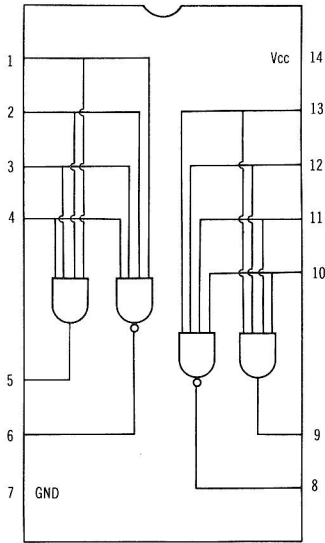

UB5

F74164PC

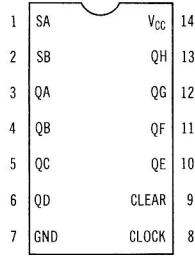

UC3

F74125PC

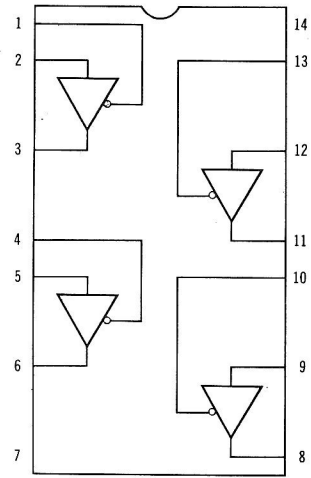

UC9

74163N

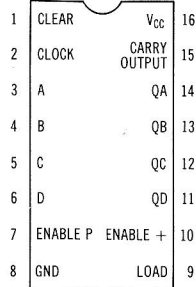

UC4,UC6

F5404DM
SN7404J

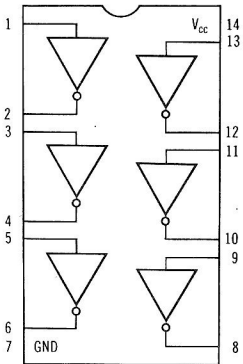

UB6,UD6,UF7,UF8,UF11

DM7410N

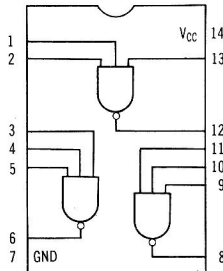

UC5,UF5

SN74154N

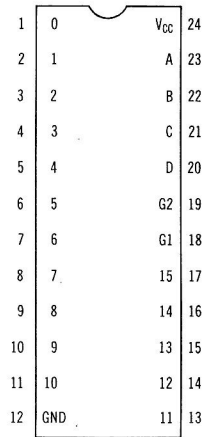

UC10

SN74165

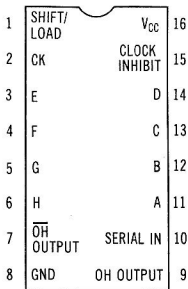

UC1

7474N

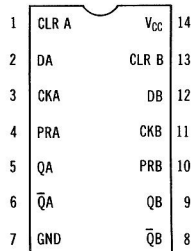

UC7,UC8,UD4,UD5,UD10,UF4

SN74393N

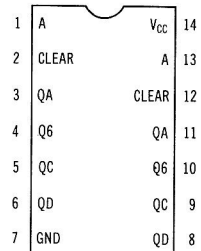

UD1

590 BOARD PINOUTS (CONTINUED)

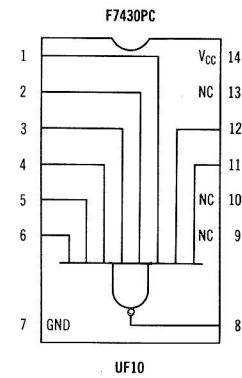
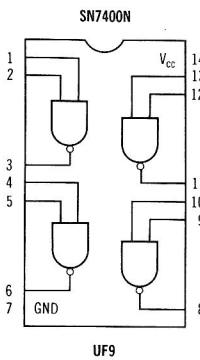
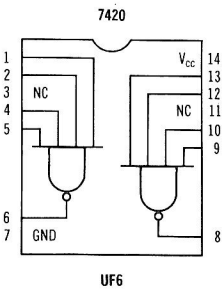
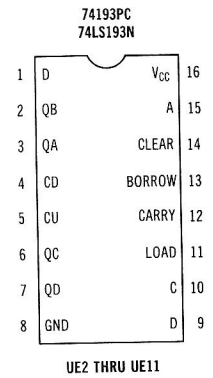
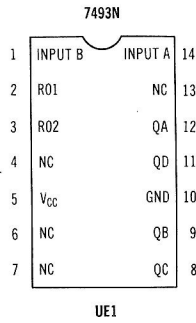
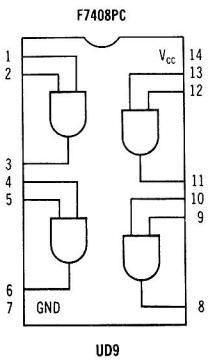
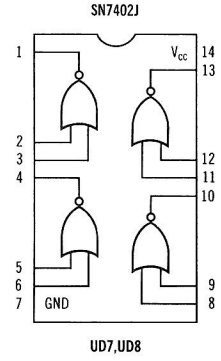
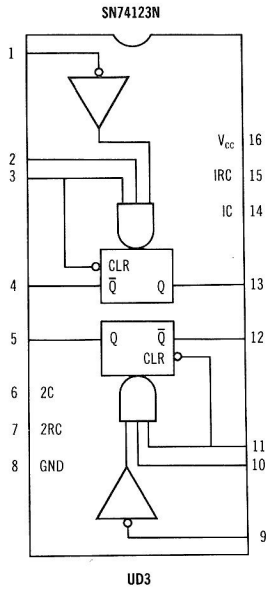
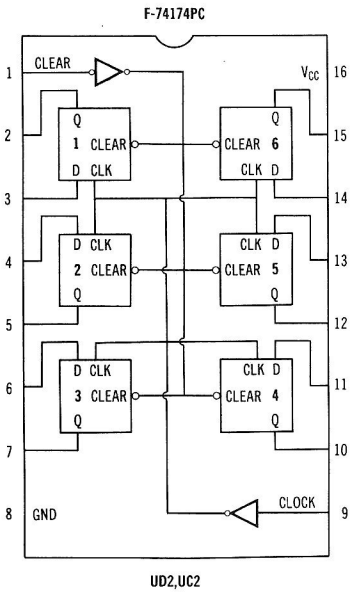

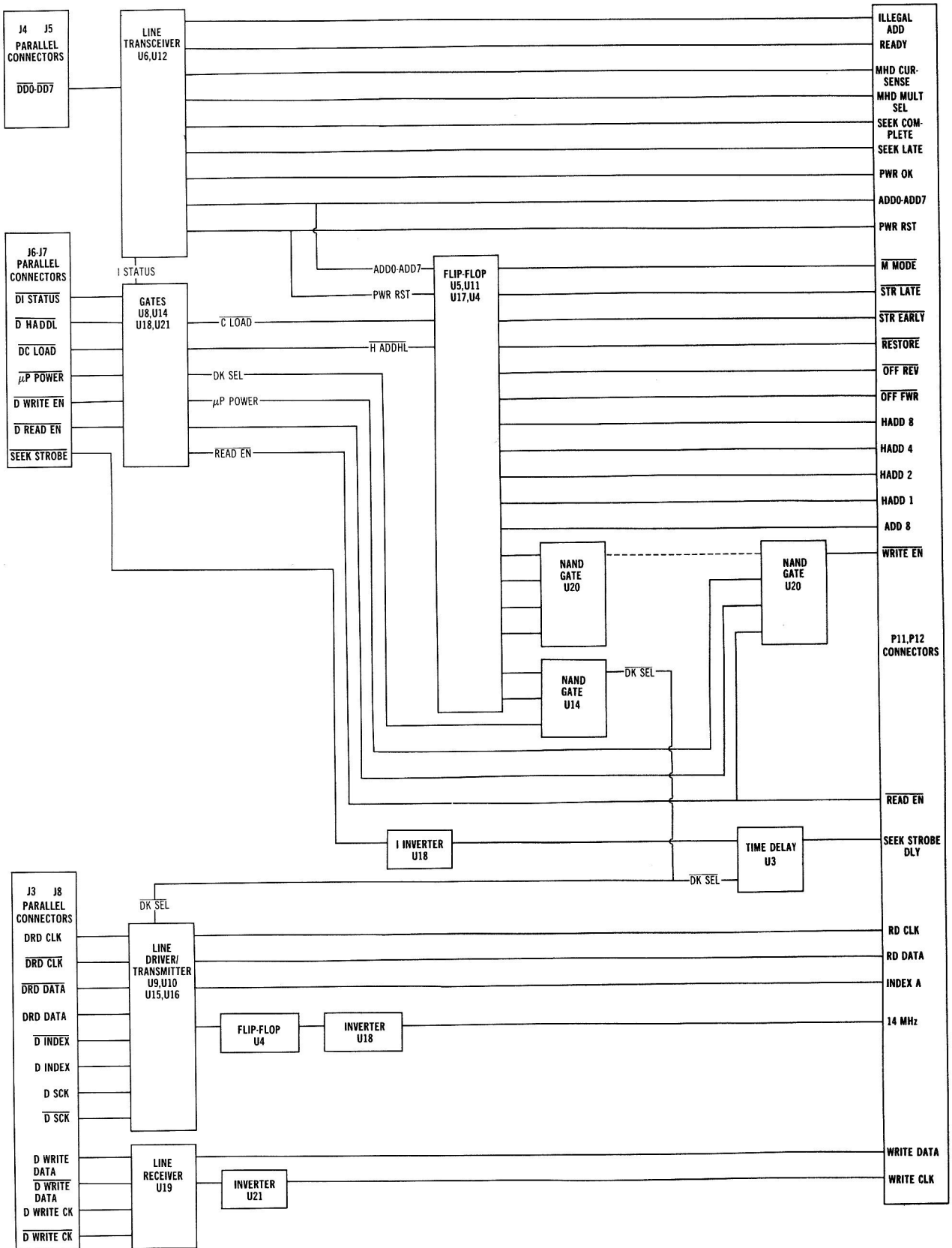

592 BOARD BLOCK

592 BOARD PINOUTS

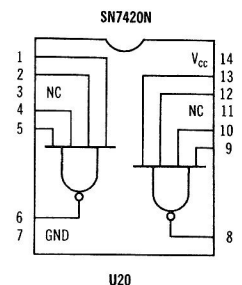
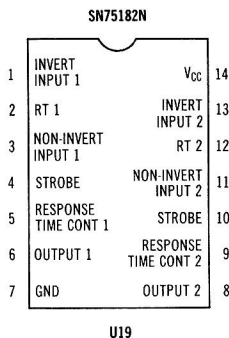
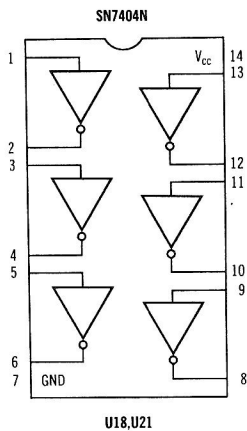
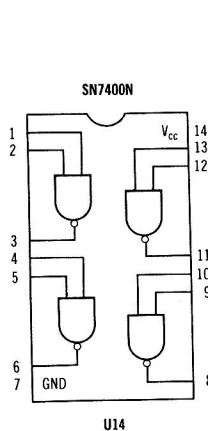
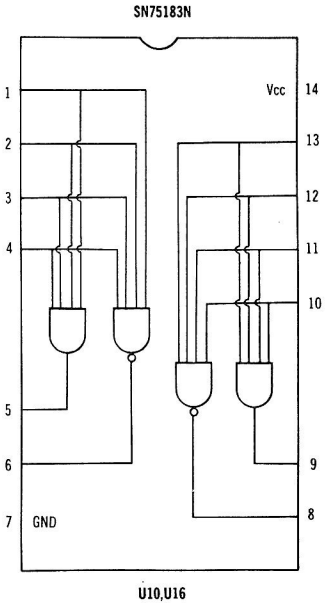
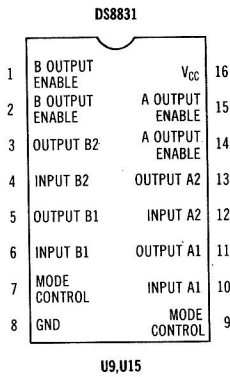
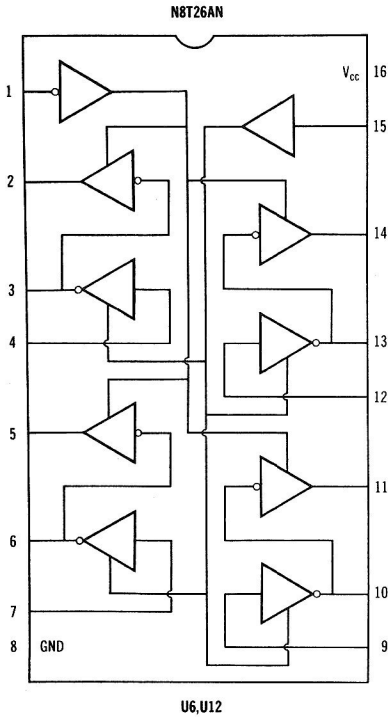
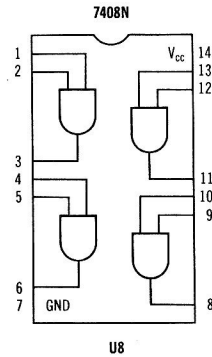
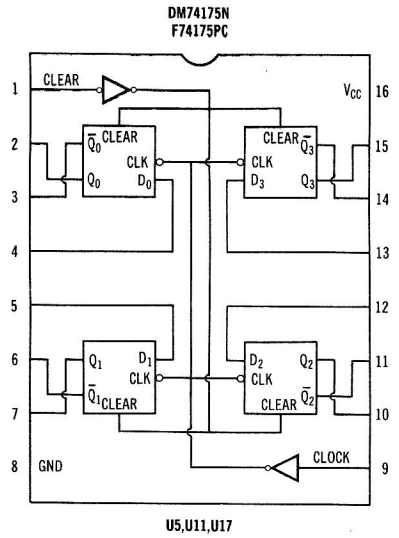
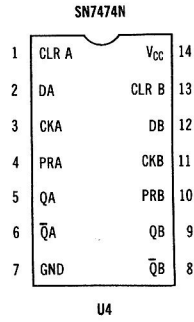
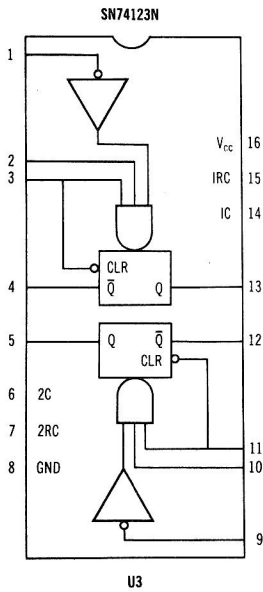

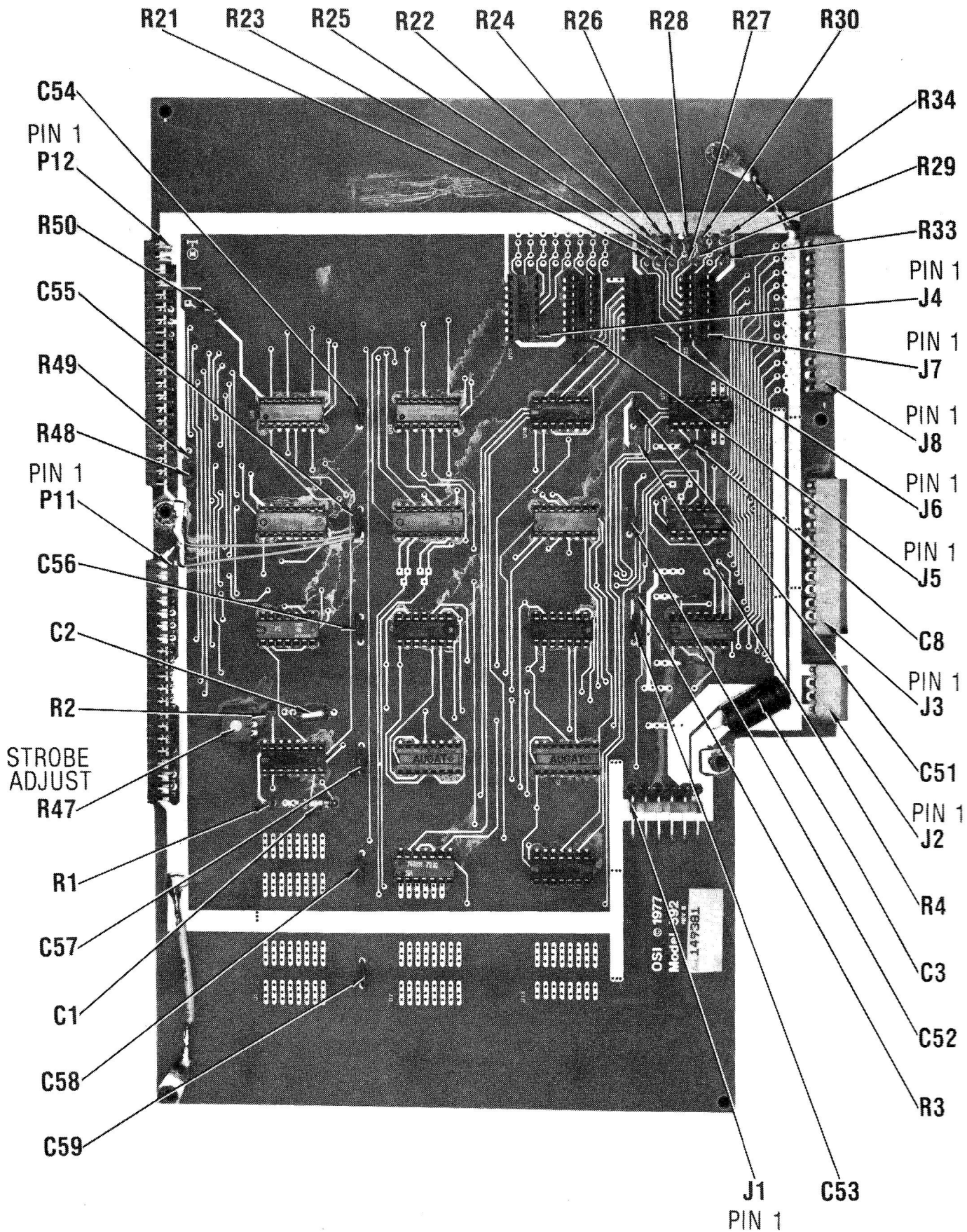

592 BOARD

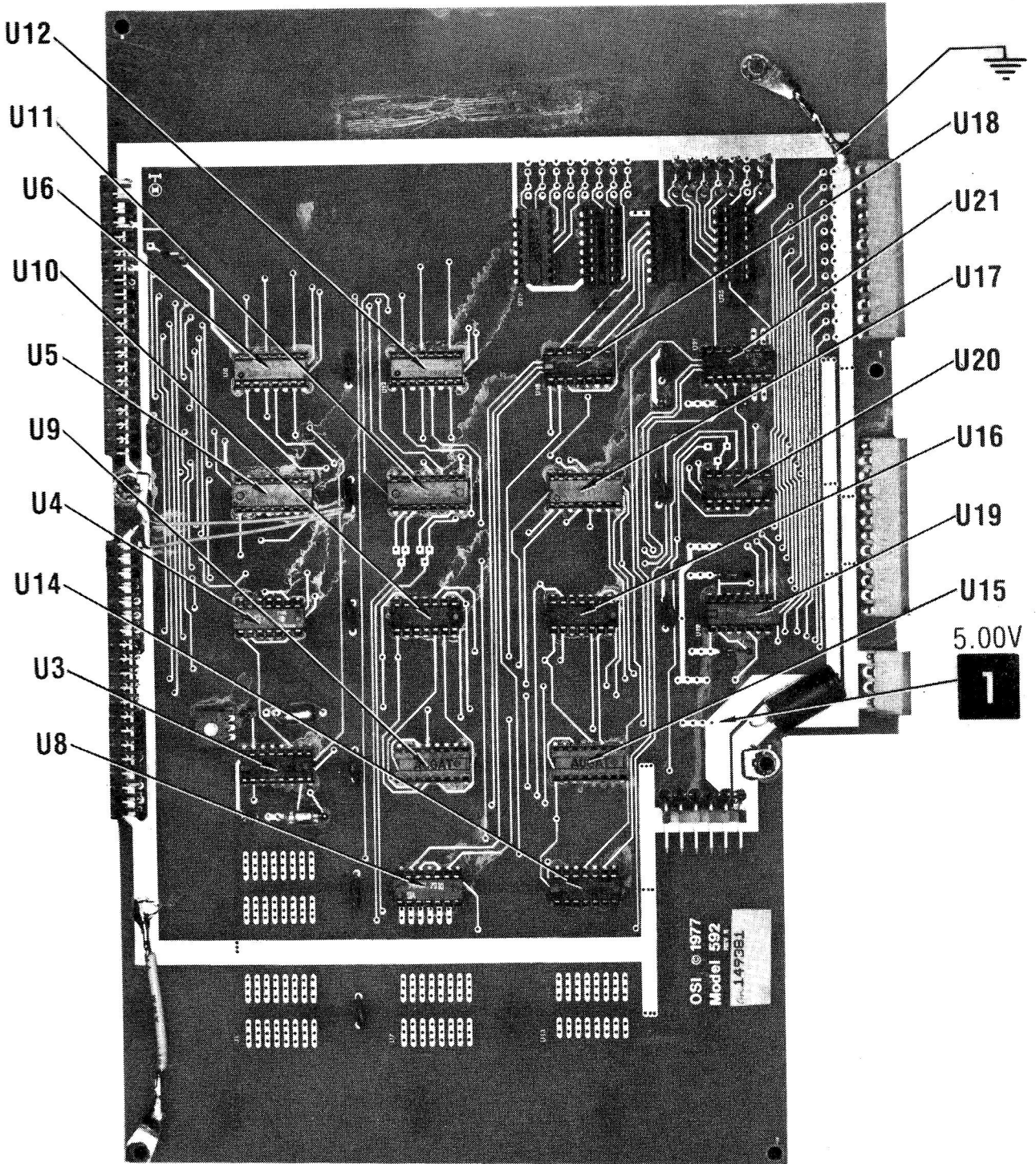

592 BOARD

A Howard W. Sams **CIRCUITRACE**® Photo

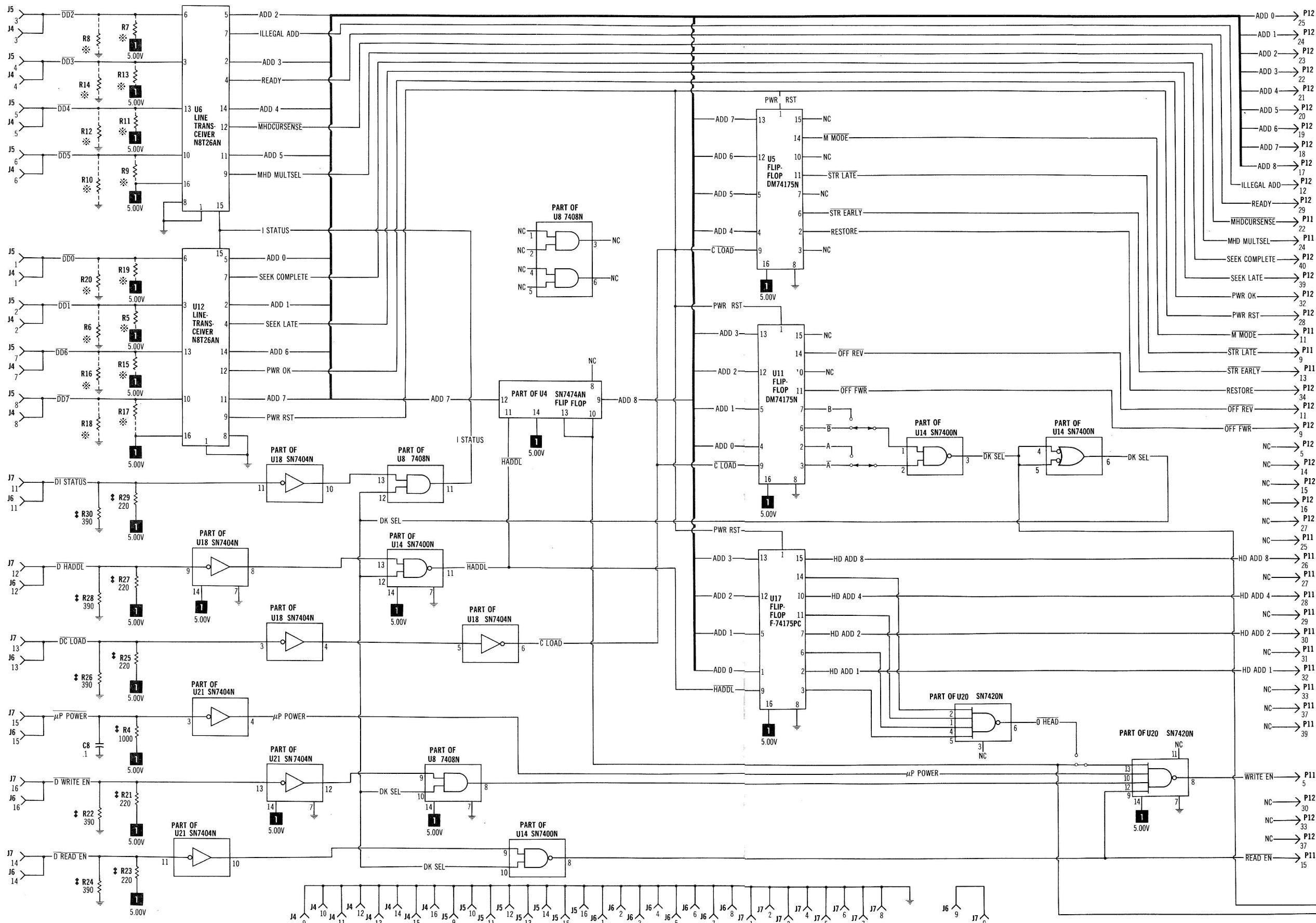

OTOFACT STANDARD NOTATION SCHEMATIC
 WITH **CIRCUITRACE™**
 © Howard W. Sams & Co., Inc. 1980

592 BOARD

FOR SCHEMATIC LEGEND AND NOTES SEE PAGES 182 & REAR COVER.

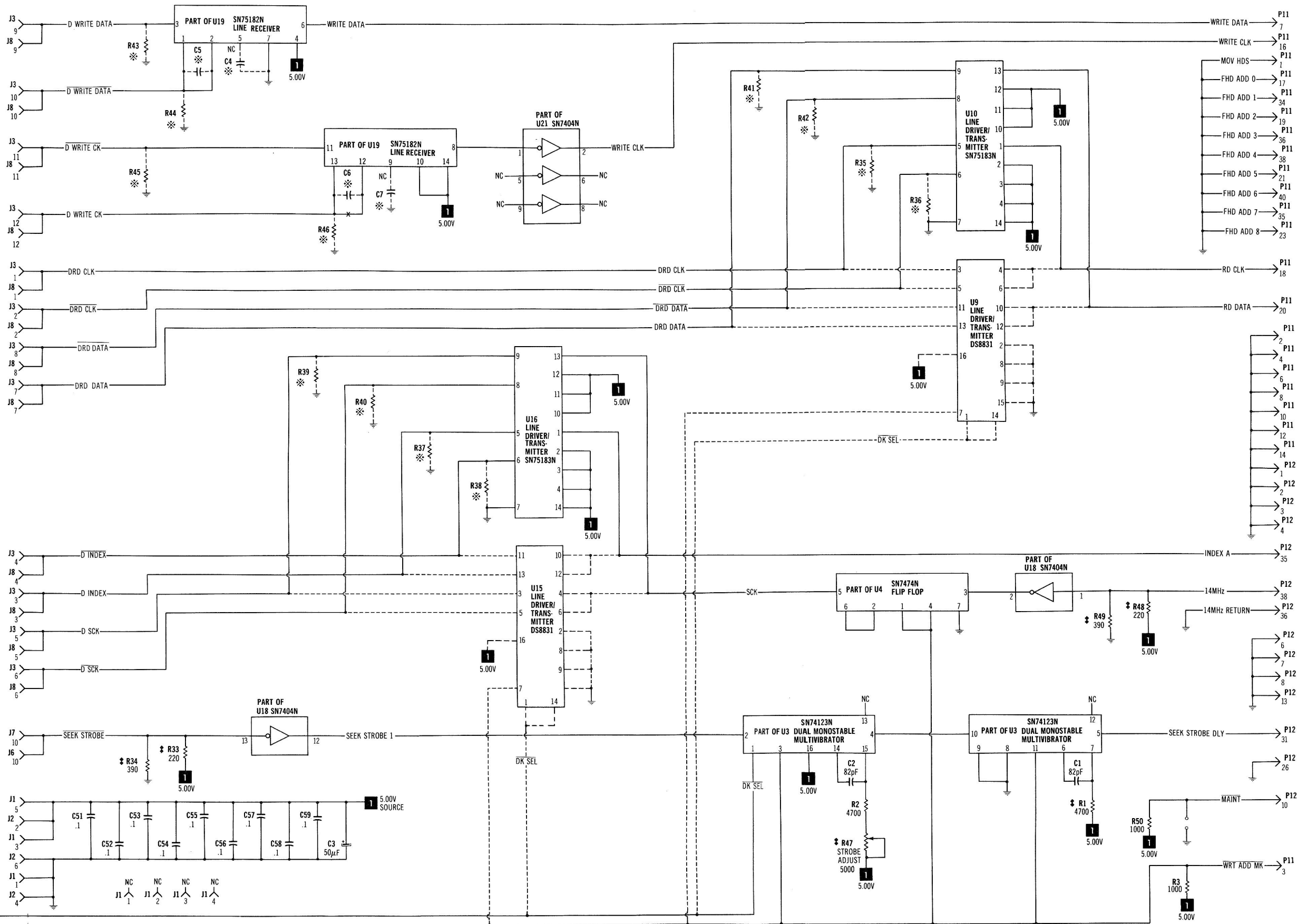

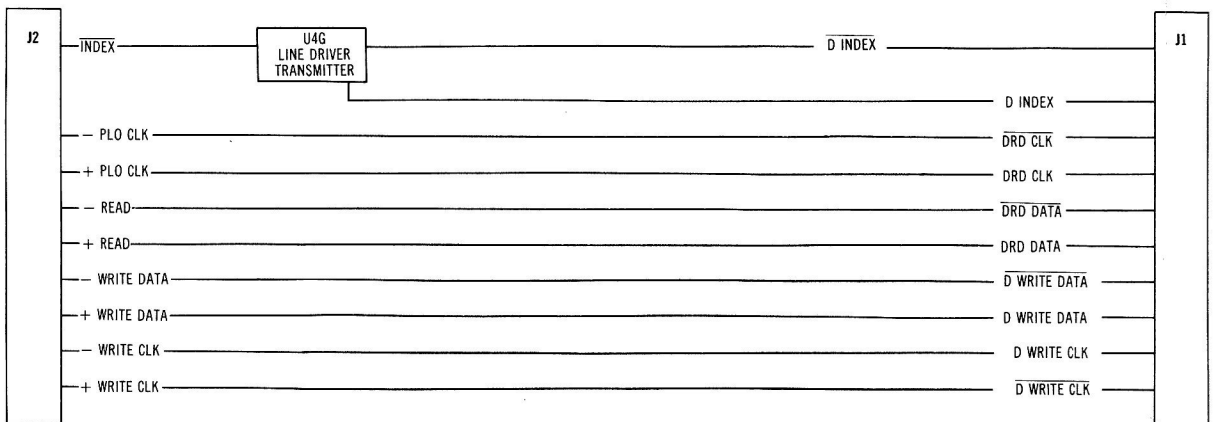
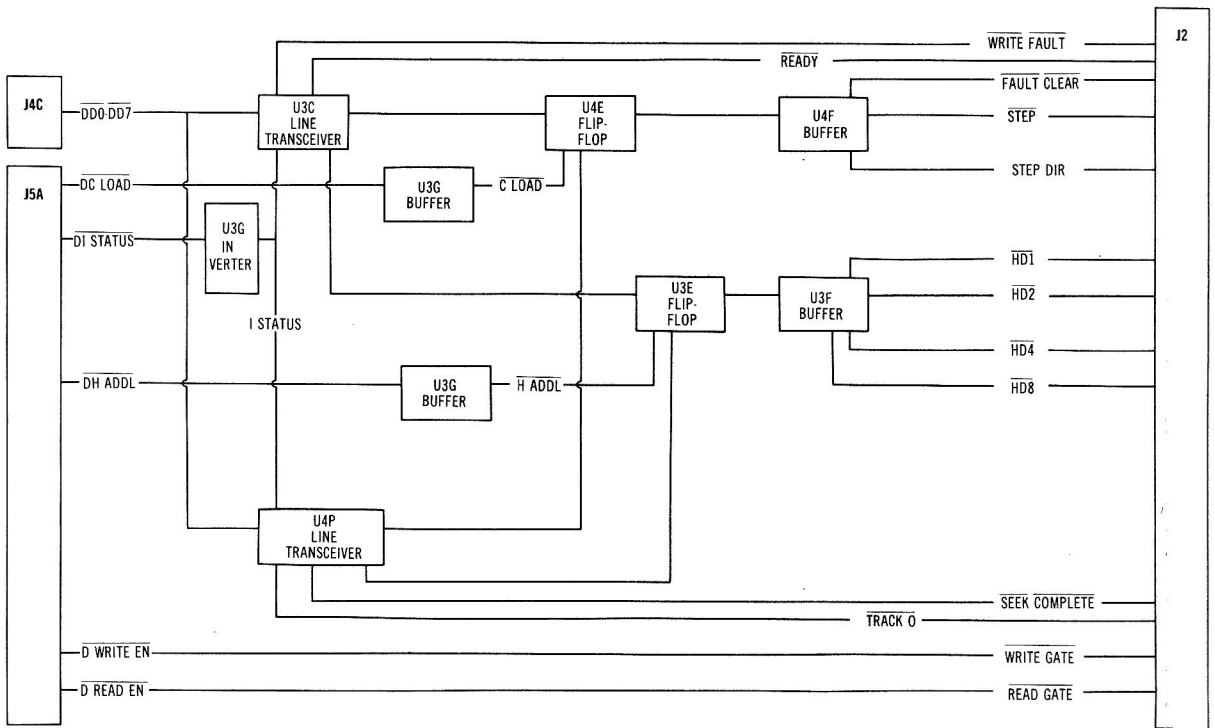

594 BOARD BLOCK

594 BOARD PINOUTS

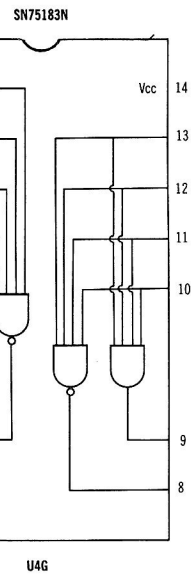
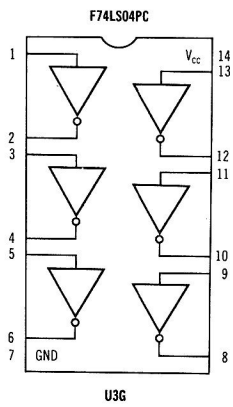
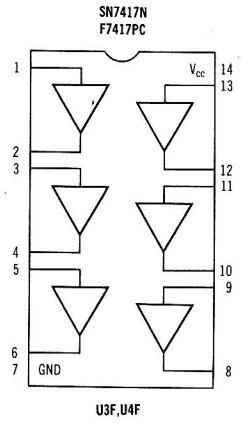
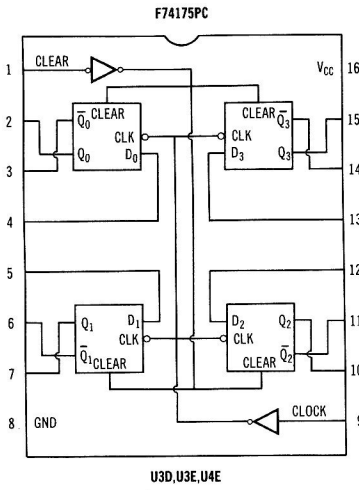
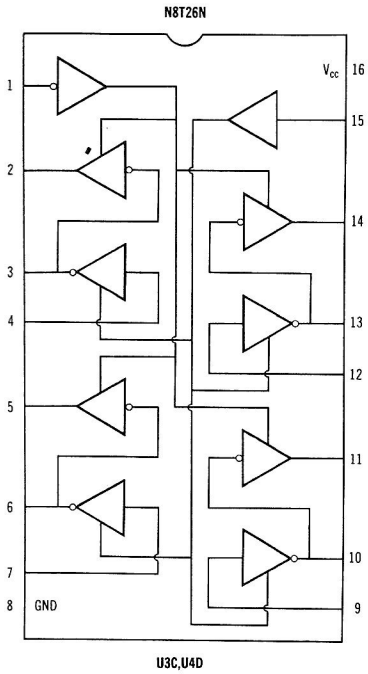

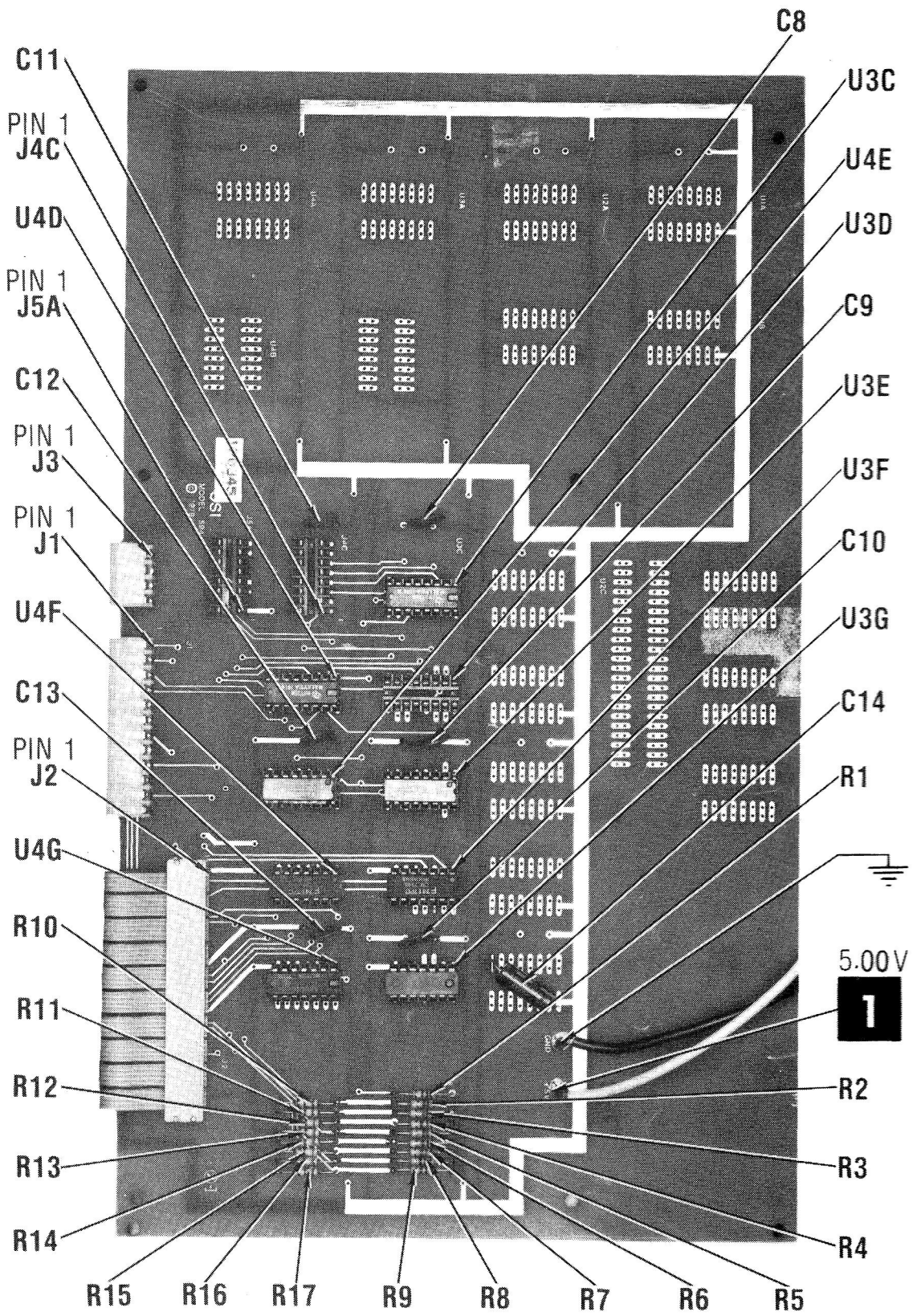

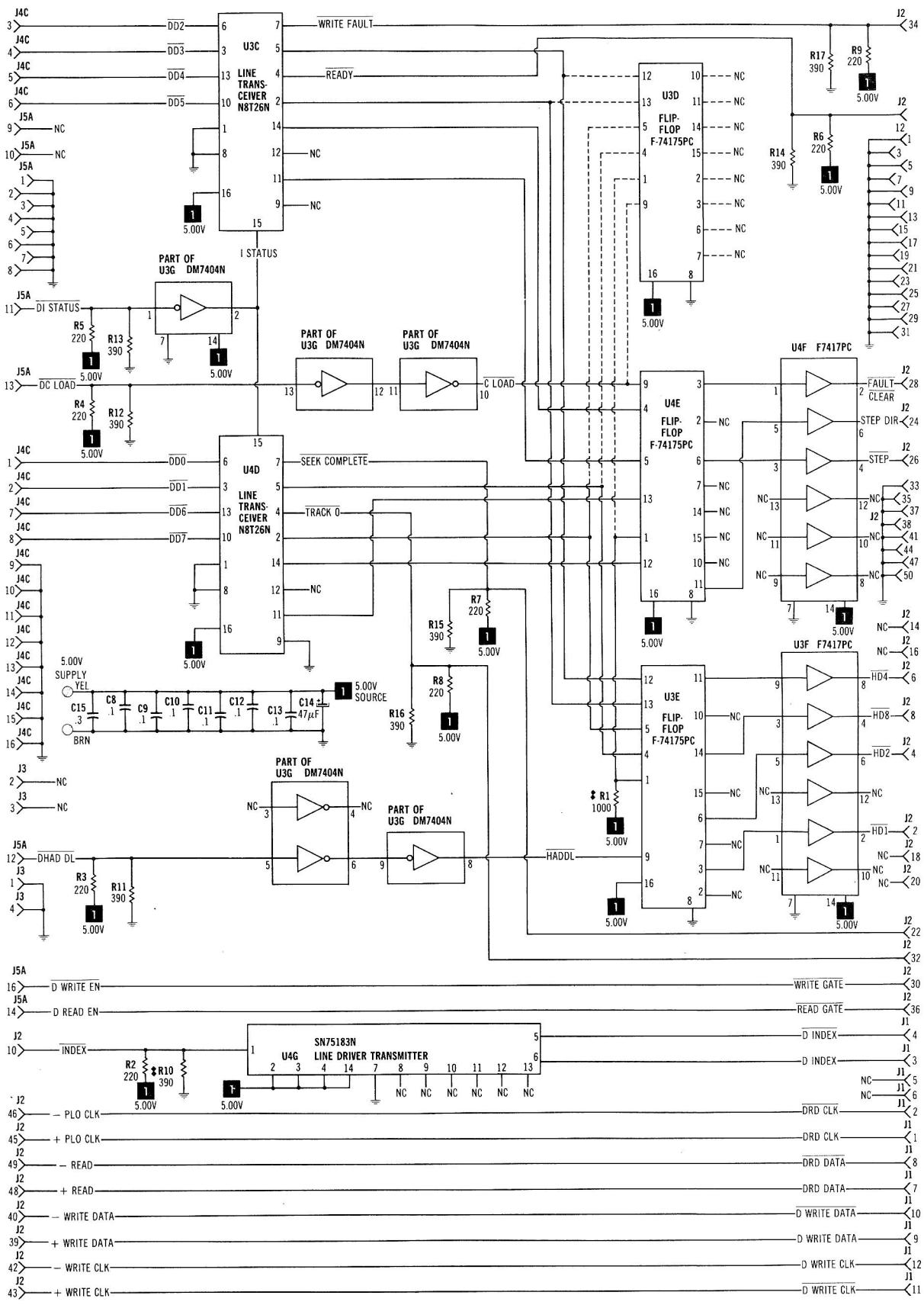

A PHOTOFAC STANDARD NOTATION SCHEMATIC

WITH **CIRCUITRACE™**

© Howard W. Sams & Co., Inc. 1980

594 BOARD

FOR SCHEMATIC LEGEND AND NOTES SEE REAR COVER.

**LEGEND FOR 470
(FLOPPY) BOARD SCHEMATIC**

A0,A1,A2 Address
A4,A5 Address
A8-A15 Address
ACS ACIA Chip Select
BE Board Enable
CA1,CA2 Peripheral A Interrupt
 Input-Control Line
CB1,CB2 Peripheral B Interrupt
 Input-Control Line
CLR Clear
DD Data Direction
D0-D7 Data
DRIVE SELECT Drive Select
ERASE ENABLE Erase Enable
FAULT Fault
FAULT RESET Fault Reset
HEAD LOAD Head Load
INDEX Index
IRQ Interrupt Request
IR/W Internal Read/Write
I $\bar{\phi}$ 2·VMA Internal Phase Two·Valid
 Memory Address
LOW CURRENT Low Current
PB0-PB7 Port B
READY DRIVE 1 Ready Drive One
READY DRIVE 2 Ready Drive Two
R/W Read/Write
SECTOR Sector
SELECT DRIVE 1 Select Drive One
 (Single-Sided Floppy Interface)
SELECT DRIVE 2 Select Drive Two
 (Single-Sided Floppy Interface)
SEPARATED CLOCK Separated Clock
SEPARATED DATA Separated Data
SIDE SELECT Side Select
 (Dual-Sided Floppy Interface)
STEP Step
STEP IN Step In
TRACK 00 Track Zero

**470 BOARD
(CONTINUED)**

TX CLK Transmit Clock
VMA Valid Memory Address
WAIT Wait
WRITE DATA Write Data
WRITE ENABLE Write Enable
WRITE PROTECT Write Protect
 $\bar{\phi}$ 2·VMA Phase Two·Valid
 Memory Address

**LEGEND FOR 505 REV. A
BOARD SCHEMATIC**

A0-A15 Address
BE Board Enable
BRG Baud Rate Generator
CA1 Control A1
CA2 Control A2
CB1 Control B1
CB2 Control B2
CLR Clear
CNT Count
CS_D Chip Select D
CS_E Chip Select E
CS_F Chip Select F
CS_{FL} Chip Select Floppy Disk
CS_S Chip Select Serial
D0-D7 Data
DD Data Direct
ERASE ENABLE Erase Enable
FAULT Fault
FAULT RESET Fault Reset
HEAD LOAD Head Load
INDEX Index
IRQ Interrupt Request
IR/W Internal Read/Write
I $\bar{\phi}$ 2·VMA Internal Phase Two·Valid
 Memory Address
LOW CURRENT Low Current

Any $\bar{\text{Bar}}$ above any alphabetical or numerical combination indicates line active in a low (0) state.

**510 BOARD
(CONTINUED)**

RX Receive Data
 RX CLK Receive Clock
 TX CLK Transmit Clock
 VMA Valid Memory Address
 WAIT Wait
 WR Z80 Write
 ϕ_{1B} Phase One(6800)
 ϕ_2 Phase Two
 ϕ_{2A} Phase Two(6502)
 ϕ_{2B} Phase Two(6800)
 ϕ_2 -VMA Phase Two-Valid
 Memory Address

**LEGEND FOR 520
REV. B BOARD SCHEMATIC**

A0-A17 Address
 CE0-CE3 Chip Enable
 D0-D7 Data
 DD Data Direction
 DI0-DI7 Data In
 D00-D07 Data Out
 R/W Read/Write
 WAIT Wait
 ϕ_2 -VMA Phase Two-Valid
 Memory Address

**LEGEND FOR 520 REV. C
BOARD SCHEMATIC**

A0-A19 Address
 MA0-MA11 Memory Address
 D0-D7 Data
 CE0-CE3 Chip Enable
 DD Data Direct
 R/W Read/Write
 MR/W Memory Read/Write

Any $\bar{\text{Bar}}$ above any alphabetical or numerical combination indicates line active in a low (0) state.

**520 BOARD
(CONTINUED)**

DI0-DI7 Data In
 D00-D07 Data Out
 WAIT Wait
 ϕ_2 -VMA Phase Two-Valid
 Memory Address

LEGEND FOR 525 BOARD SCHEMATIC

BA0-BA19 Backplane Address
 BD0-BD7 Backplane Data
 BBE Backplane Bus Enable
 BIE Backplane Input Enable
 BR/W Backplane Read/Write
 B ϕ_2 VMA Backplane Phase Two-Valid
 Memory Address
 CA0-CA19 Port Address
 CBE Port Bus Enable
 CD0-CD7 Port Data
 CE0-CE15 Chip Enable For RAM
 CIE Port Input Enable
 CR/W Port Read/Write
 C ϕ_2 VMA Port Phase Two-Valid
 Memory Address
 DD_B Data Direct Backplane
 DD_P Data Direct Port
 MA0-MA13 Memory Address
 MD0-MD7 Memory Data
 MR/W Memory Read/Write
 PC Port Control
 PS Port Status
 WAIT_B Wait Backplane
 WAIT_P Wait Port

LEGEND FOR 527 BOARD SCHEMATIC

A0-A19 Address
 CE0-CE23 Chip Enable RAM

**527 BOARD
(CONTINUED)**

DD Data Direct
 D0-D7 Data
 IR/W Internal Read/Write
 MM Memory Management
 R/W Read/Write
 VMA Valid Memory Address
 WAIT Wait
 Y0-Y1-Y2 Upper Memory Decode
 Ø0 Phase Zero
 Ø2·VMA Phase Two·Valid
 Memory Address

LEGEND FOR 535 BOARD SCHEMATIC

A0-A19 Address
 BE Bus Enable
 D0-D7 Data
 DD Data Direct
 DI0-DI7 Data In
 DL1-DL16 Delay
 D00-D07 Data Out
 E2 Enable Two
 IØ2 Internal Phase Two
 IR/W Internal Read/Write
 MA0-MA6 Memory Address
 RAS0-RAS2 Row Address Strobe
 RE Row Enable
 R/W Read/Write
 Ø0IN Phase Zero In
 Ø2 Phase Two
 Ø2·VMA Phase Two·Valid
 Memory Address
 ØDETECT Phase Detect

LEGEND FOR 550 BOARD SCHEMATIC

A0 Address Zero
 A1-A4 Address

Any $\overline{\text{Bar}}$ above any alphabetical or numerical combination indicates line active in a low (0) state.

**550 BOARD
(CONTINUED)**

A8-A19 Internal Data
 BE Bus Enable
 BRG Baud Rate Generator
 CS1-CS16 Chip Select
 D0-D7 Data
 DD Data Direct
 DE Data Enable
 IA0 Internal Address Zero
 ID0-ID7 Internal Data
 IRQ Interrupt Request
 IR/W Internal Read/Write
 IØ2·VMA Internal Phase Two·Valid
 Memory Address
 R/W Read/Write
 SPR-I Spare In
 SPR-O Spare Out
 WAIT Wait
 Ø2·VMA Phase Two·Valid
 Memory Address

LEGEND FOR 555 BOARD SCHEMATIC

A0-A15 Address
 ACK Acknowledge
 ACS0-ACS3 ACIA Chip Select
 ACS15 ACIA Chip Select
 BUSY Busy
 CARRIAGE READY Carriage Ready
 CARRIAGE STROBE Carriage Strobe
 CE0-CE7 Chip Enable
 CHECK Check
 DATA 1-DATA 8 Data Lines
 (Centronics Interface)
 D0-D7 Data
 DD Data Direct
 DL1-DL12 Data Line (NEC Interface)
 FAULT Fault
 F4XX Address F4XX₁₆

**592 BOARD
(CONTINUED)**

PWR RST Power Reset
 RDCLK Read Clock
 RDDATA Read Data
 READ EN Read Enable
 READY Ready
 RESTORE Restore
 SCK Servo Clock
 SEEK COMPLETE Seek Complete
 SEEK LATE Seek Late
 SEEK STROBE Seek Strobe
 SEEK STROBE DLY ... Seek Strobe Delayed
 SEEK STROBE 1 Seek Strobe One
 STR EARLY Strobe Early
 STR LATE Strobe Late
 μ P POWER Microprocessor Power
 WRITE CLK Write Clock
 WRITE DATA Write Data
 WRITE EN Write Enable
 WRT ADD MK Write Address Mark
 0 HEAD Zero Head

LEGEND FOR 594 BOARD SCHEMATIC

C LOAD Control Load
 D INDEX Disk Index
 D HADDL Disk Head Address Load
 D READ EN Disk Read Enable
 D WRITE CLK Disk Write Clock
 D WRITE DATA Disk Write Data
 D WRITE EN Disk Write Enable
 DC LOAD Disk Control Load

**594 BOARD
(CONTINUED)**

DD0-DD7 Disk Data
 DI STATUS Disk Input Status
 DRD CLK Disk Read Clock
 DRD DATA Disk Read Data
 FAULT CLEAR Fault Clear
 HADDL Head Address Load
 HD1, HD2, HD4, HD8 Head Selection
 Address Lines
 I STATUS Input Status
 PLO CLK Phase Lock Osc Clock
 READY Ready
 SEEK COMPLETE Seek Complete
 STEP DIR Step Direction
 TRACK 0 Track Zero
 WRITE CLK Write Clock
 WRITE FAULT Write Fault

SCHEMATIC NOTES

- *— Circuitry not used in some versions.
- Circuitry used in some versions.
- ⊗ Optional part. Value determined by application
- ⊕ Ground
- ▽ Common tie point
- /// Chassis
- ◆ Flame retardant resistor
- ⓔ See parts list

Item numbers in rectangles appear in the alignment/adjustment instructions.
 Supply voltage maintained as shown in input.
 Voltages measured with digital meter.
 Terminal identification may not be found on unit.
 Resistors are 1/4W or less, 5% unless noted.
 Value in () used in some versions.

Any $\bar{\text{Bar}}$ above any alphabetical or numerical combination indicates line active in a low (0) state.

ENGINEERING & CONSULTING SERVICES
1000 W. MAIN ST. N.W.
CANTON, OHIO, N. D.

OHIO SCIENTIFIC

**1333 S. Chillicothe Road
Aurora, Ohio 44202**

\$39.00

TM-300